

Electron Configurations

What is the electron structure in an atom?

Why?

The electron structure of an atom is very important. Scientists use the electronic structure of atoms to predict bonding in molecules, the charge(s) an atom might have, and the physical properties of elements. In order for scientists to describe the electron structure in an atom, they give the electrons "addresses." Just like your address might include your house number, street, city, and state, an electron's "address" has multiple parts. In this activity, you will learn how the electrons fill up the available spaces in an atom and how their "addresses" or configurations are assigned.

Model 1 – The Boarding House

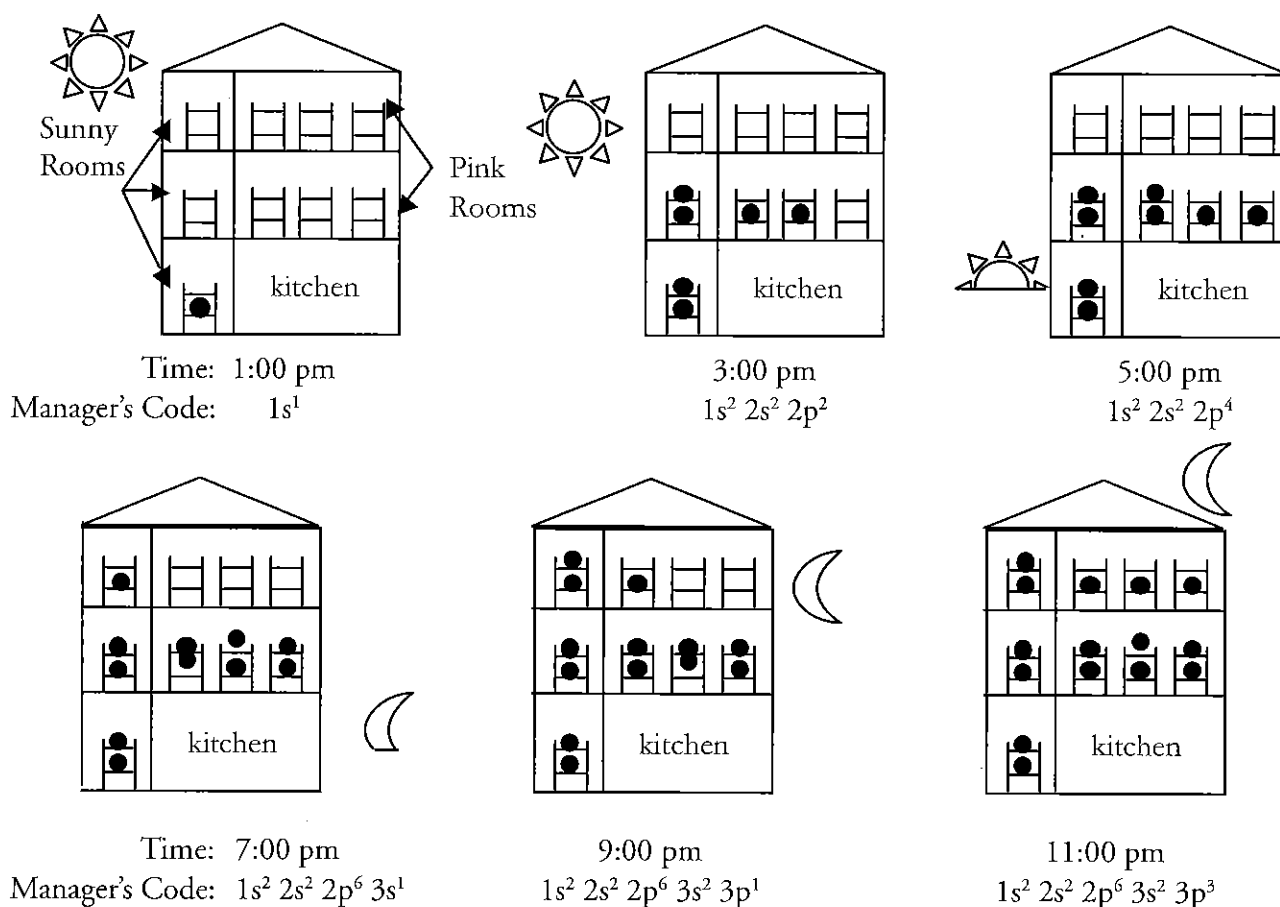

1. Examine the boarding house diagrams in Model 1. Match each symbol below with its most likely meaning.

III. a. ●

I. b. □

II. c. $1s^2 2s^2 2p^6 3s^1$

I. Bunk bed for boarders

II. Manager's code for the number of boarders in the house and their room assignments.

III. Boarder

2. Refer to Model 1.

a. How many boarders were in the boarding house at 5:00 pm?

8

b. Describe how you determined your answer to part a.

Count the number of •s in the house at five o'clock.

3. Examine each diagram in Model 1 and the corresponding manager's code. Using the following manager's code:

$1\textcircled{S}^2$ $2\textcircled{S}^2$ $2\textcircled{P}^4$

a. Underline the floor numbers.

b. Circle the types of rooms.

c. Draw a box around the numbers of boarders.

4. The manager of the boarding house has some very strict rules on how beds will be rented out for the night. Examine the diagrams in Model 1 and the statements below to determine the phrase that best describes the manager's set of rules. Circle the correct answer.

a. The boarding house will rent out beds on the _____ floor first.

$\textcircled{1\text{st}}$ 2nd 3rd

b. Boarders are only allowed to double up in a bunk when _____
there is an even number of boarders in the room $\textcircled{\text{all bottom bunks are occupied}}$

c. The next floor of rooms will be opened for boarders only when _____
on the floor below are occupied.

half of the bunks at least one of the rooms $\textcircled{\text{all of the bunks}}$

d. The pink room on a floor will be opened for boarders only when _____
all of the lower bunks in the sunny room on that floor are occupied

$\textcircled{\text{all of the bunks in the sunny room on that floor are occupied}}$

the sunny room on that floor is open



5. Provide (a) the manager's code and (b) a boarding house diagram showing 12 boarders present.

a. $1s^22s^22p^63s^2$

b.

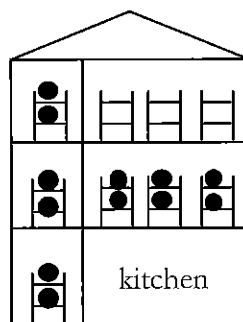

Model 2 – Ground State Orbital Diagrams and Electron Configurations

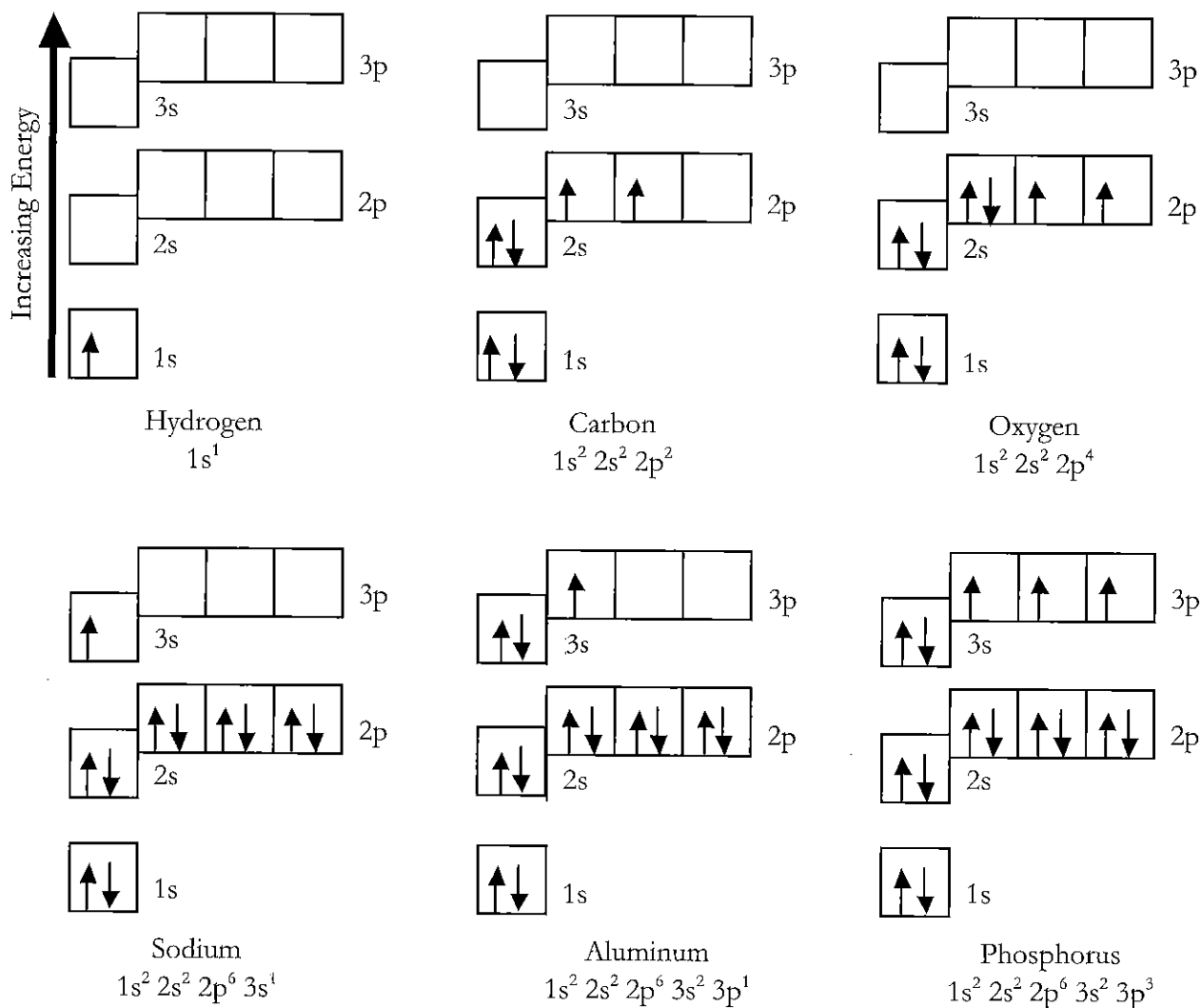

6. Examine the orbital diagrams and electron configurations in Model 2. Match each symbol below with its meaning.

III a.

I. Single electron

I b. ↑

II. Pair of electrons with opposite spins

II c. ↑↓

III. Atomic orbital (region of space where an electron is likely to be found)

IV d.

IV. Sublevel (set of orbitals having equivalent energy)

V e. $1s^2 2s^2 2p^4$

V. Electron configuration

7. Consider the orbital diagram for oxygen in Model 2.

a. How many electrons are present in the orbital diagram?

Eight electrons are present.

b. Based on its position in the periodic table, explain how you know that your answer to part a is the *correct* number of electrons for oxygen.

The atomic number of oxygen is 8.

8. Examine the orbital diagrams and electron configurations in Model 2. Using the following electron configuration:

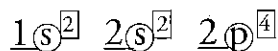

a. Underline the energy levels.

b. Circle the sublevels.

c. Draw a box around the numbers of electrons.

9. The 2s and 2p sublevels are very close in energy, as are the 3s and 3p sublevels. Explain how the orbital diagram for sodium confirms that the 3s sublevel is lower in energy than the 3p sublevel.

The s sublevel is located lower on the page than the p sublevel.

10. The lowest potential energy arrangement of electrons in an atom is called the **ground state**. Ground state electron configurations can be predicted by a strict set of rules known as the **Aufbau principle** (“aufbau” means filling up). Examine the diagrams in Model 2 and the statements below to determine the phrase that best describes each rule. Circle the correct answer.

a. Based on where a single electron is placed, the lowest potential energy electron in an atom is found in the _____ sublevel.

1s 2s 3s

b. Electrons will occupy a p-orbital only after _____ .
the previous s-orbital is half full

the previous s-orbital is completely full

the previous s-orbital is empty

c. Electrons can begin to occupy energy levels with the next highest integer designation (e.g., 2 vs. 1, 3 vs. 2) only after _____ on the energy level below it are occupied.

half of the orbitals

at least one of the orbitals

all of the orbitals

11. The **Pauli exclusion principle** describes the restriction on the placement of electrons into the same orbital. The Pauli exclusion principle can be expressed as: "If two electrons occupy the same orbital, they must have _____." Circle the correct answer.

the same spin

opposite spins

12. **Hund's rule** describes how electrons are distributed among orbitals of the same sublevel when there is more than one way to distribute them. Hund's rule consists of two important ideas. Based on Model 2, circle the correct answer to each statement.

a. Electrons will pair up in an orbital only when _____.

there is an even number of electrons in the sublevel

all orbitals in the same sublevel have one electron

b. When single electrons occupy different orbitals of the same sublevel, _____.

they all have the same spin

they all have different spins

their spins are random

13. For each of the symbols below from Model 2, provide the name or description of the analogous component that was used in the boarding house model (Model 1).

a.

□	<i>Bunk beds for boarders</i>
□ □ □	<i>Pink room</i>
↑	<i>One boarder</i>
↑↓	<i>Two boarders</i>
$1s^2 2s^2 2p^4$	<i>Manager's code</i>

- b. What characteristic of electrons is *not* well represented by the boarding house model?

There is no analogy for electron spin in the boarding house model.

The s and p rooms are on the same floor but s and p orbitals don't have the same energy.

- c. How could the boarding house model be modified to better represent the relative energies of s and p sublevels?

Place steps going into the p sublevel to show that it is slightly higher than the s sublevel. Also, boarders in the bunks could sleep head-to-foot rather than in the same direction.



14. Below are three answers generated by students in response to the prompt: "Provide an orbital energy level diagram for the ground state of a nitrogen atom." In each case, indicate whether the answer is right or wrong, and if it is wrong, explain the error.

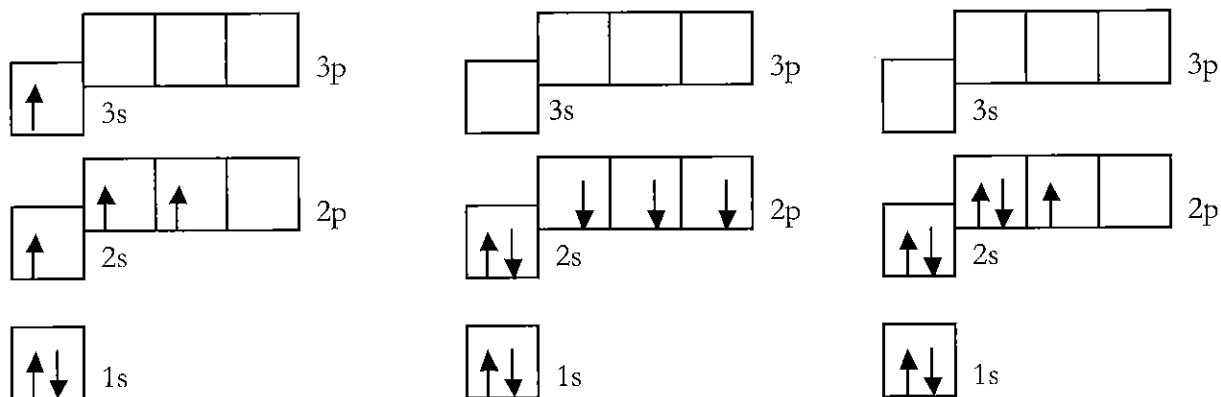

<p>a. Wrong; electrons are in the third energy levels when the previous orbitals are not full—violation of the Aufbau principle.</p>	<p>b. Correct; single electrons can be in either the "up" or "down" position.</p>	<p>c. Wrong; two electrons have been placed into the same orbital when all orbitals in the sublevel do not have one electron—violation of Hund's rule.</p>
--	---	--

15. Complete the ground state orbital energy level diagrams and write the corresponding electron configurations for:

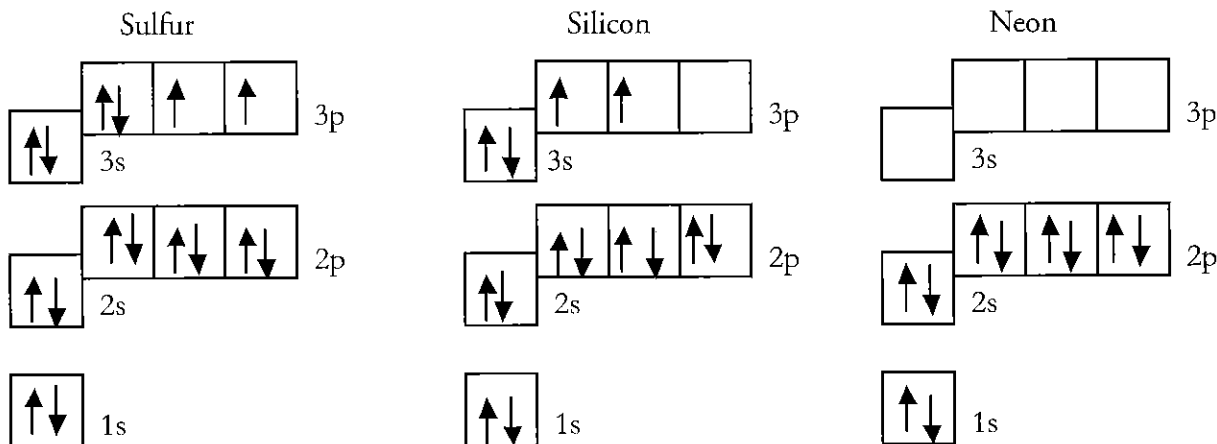

<p>Sulfur</p> $1s^2 2s^2 2p^6 3s^2 3p^4$	<p>Silicon</p> $1s^2 2s^2 2p^6 3s^2 3p^2$	<p>Neon</p> $1s^2 2s^2 2p^6$
--	---	------------------------------



Extension Questions

Model 3 – Orbital Diagram for an Atom of Element X

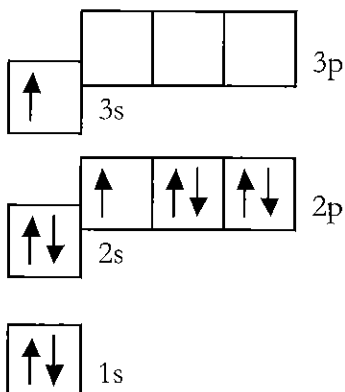

16. Consider the orbital diagram in Model 3.

a. How many electrons are there in one atom of element X?

10 electrons

b. Identify element X and provide its ground state electron configuration. Assume the atom is neutral.

Element X is neon and its ground state electron configuration is $1s^2 2s^2 2p^6$.

c. Is the arrangement of electrons in the orbital diagram in Model 3 higher in total potential energy or lower in total potential energy than the ground state electron configuration of element X? Explain your reasoning.

The orbital diagram in Model 3 is higher in energy than the ground state because there is an electron in the 3s orbital that should be in a 2p orbital. The electron would need to have higher potential energy to be in the 3s orbital.

Read This!

An **excited state electron configuration** is *any* electron configuration for an atom that contains the correct total number of electrons but has a higher total electron potential energy than the ground state electron configuration.

17. Write an electron configuration for element X that shows the atom in a different excited state than the one illustrated in Model 3.

Many alternatives exist: $1s^2 2s^1 2p^6 3s^1$, etc.

18. Each orbital diagram shown below describes an excited state of an atom of a *different* element. Use the orbital diagrams to complete the table.

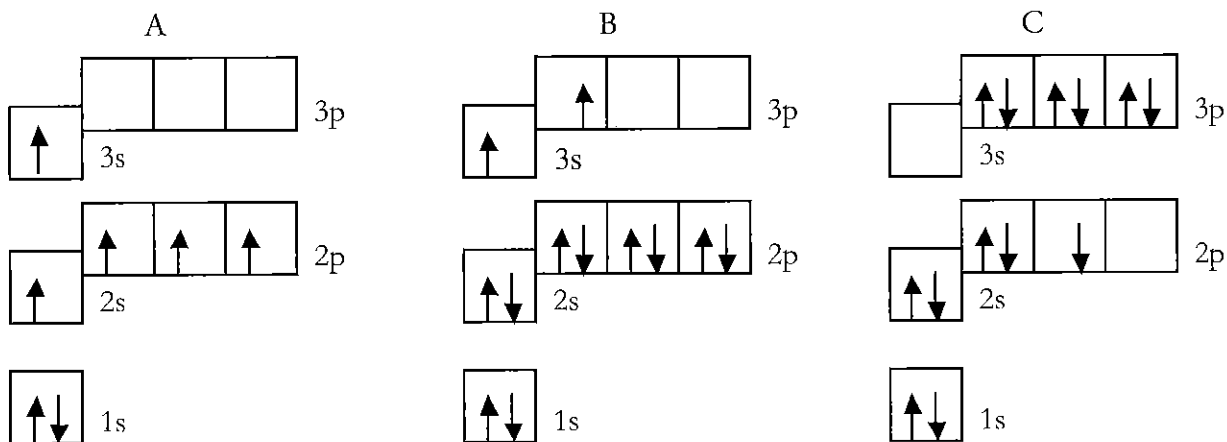

	A	B	C
Excited state electron configuration	$1s^2 2s^1 2p^3 3s^1$	$1s^2 2s^2 2p^6 3s^1 3p^1$	$1s^2 2s^2 2p^3 3p^6$
Identify the element	<i>Nitrogen</i>	<i>Magnesium</i>	<i>Aluminum</i>
Ground state electron configuration	$1s^2 2s^2 2p^3$	$1s^2 2s^2 2p^6 3s^2$	$1s^2 2s^2 2p^6 3s^2 3p^1$

19. Complete the table for each of the excited state electron configurations given.

Excited state electron configuration	Element name	Ground state electron configuration	Orbital diagram for ground state
$1s^2 2s^1 2p^2$	<i>Boron</i>	$1s^2 2s^2 2p^1$	
$1s^2 2s^2 2p^3 3s^2 3p^1$	<i>Fluorine</i>	$1s^2 2s^2 2p^5$	